

BADLANDS Illuminator Pro-III Metric RUN-BRAKE-TURN with built in Self Canceling Module

Thank you for purchasing a Badlands Illuminator Pro-III Metric Module! We're sure that you will be completely satisfied with the performance and ease of installation of your new module. Before you get started, PLEASE read these instructions and helpful tips so that you understand how to install your module correctly. This module will NOT work on Honda Motorcycles or models with ABS braking systems. An improper installation will void the warranty.

This is not a simple job by any means, even for a skilled professional. Proper planning is needed along with understanding more than basic motorcycle wiring. Be sure to consult with a service manual before attempting this installation.

FEATURES: All Badlands Illuminator Pro-III Metric Modules are designed to provide you running light and turn signal functions to each of the front turn signals, running light, brake light and turn signal functions to each rear turn signal all on (1) wire per signal. The ILL-PRO-III-M also has left and right indicator light outputs for factory or custom turn signal indicator options. These modules are designed with a built-in 11-second Self Canceling feature which is perfect for all custom applications. Lastly, you do not need a Load Equalizer when using small incandescent bulbs, Halogen or LED turn signals (*up to 50-watts per bulb or 200-watts total*) since the ILL-PRO-III-M operates all lighting styles. Now you understand the features of our Illuminator Module, let's talk about how it works.

MODULE WIRING: The ORANGE/WHITE wire on our module needs 12-volt switched or battery power. (**NOTE, we recommend to connect the ORANGE/WHITE (+) wire from our ILL-PRO-III directly to the battery with a 7.5 AMP fuse or to a circuit breaker. The BLACK (-) wire should be grounded to the frame or to the ground (-) post on the battery.**)

INSTALLATION: You can use any installation method you choose but **DISCONNECT** the battery **FIRST!** We package this module with male & female spade terminals and quick splices but we recommend using connectors and terminals whenever possible. ALL (4) output wires from the ILL-PRO-III-M will have an automatic, self canceling, 11-second flashing function.

- **NOTE:** If you are installing this module on a motorcycle with a flasher system built into the ECM, the INPUT wires (*from switches*) and OUTPUT (*bike harness to front & rear turn signals*) wiring will need to be identified and removed from the ECM and connected to our module as described below. **BEFORE you remove/de-pin or cut these wires, please consult with your dealer or service manual to be sure this will not affect the function of the ECM.**

- **NOTE:** If your model does not have a combined ECM flasher unit, it is wired with a mechanical flasher. For this module to operate properly, find the mechanical flasher, unplug it and twist the (2) hot wires together and disregard the ground. This will provide switched 12-volt (+) power to your turn signal switches as outlined below. The motorcycle wiring (*from switches*) and wiring to the front and rear turn signals will need to be identified and connected to our module as described below.

- **NOTE:** If your turn signal indicator has only one light that illuminates for the LEFT and RIGHT turn signal functions, you will need to install diodes onto the WHITE and GREEN wire from the module. (*Part number 1N400X1 through 7 which is available from your local electronics store.*) Once connected, attach the other end of the diodes to each other then attach to the single wire on the indicator light.

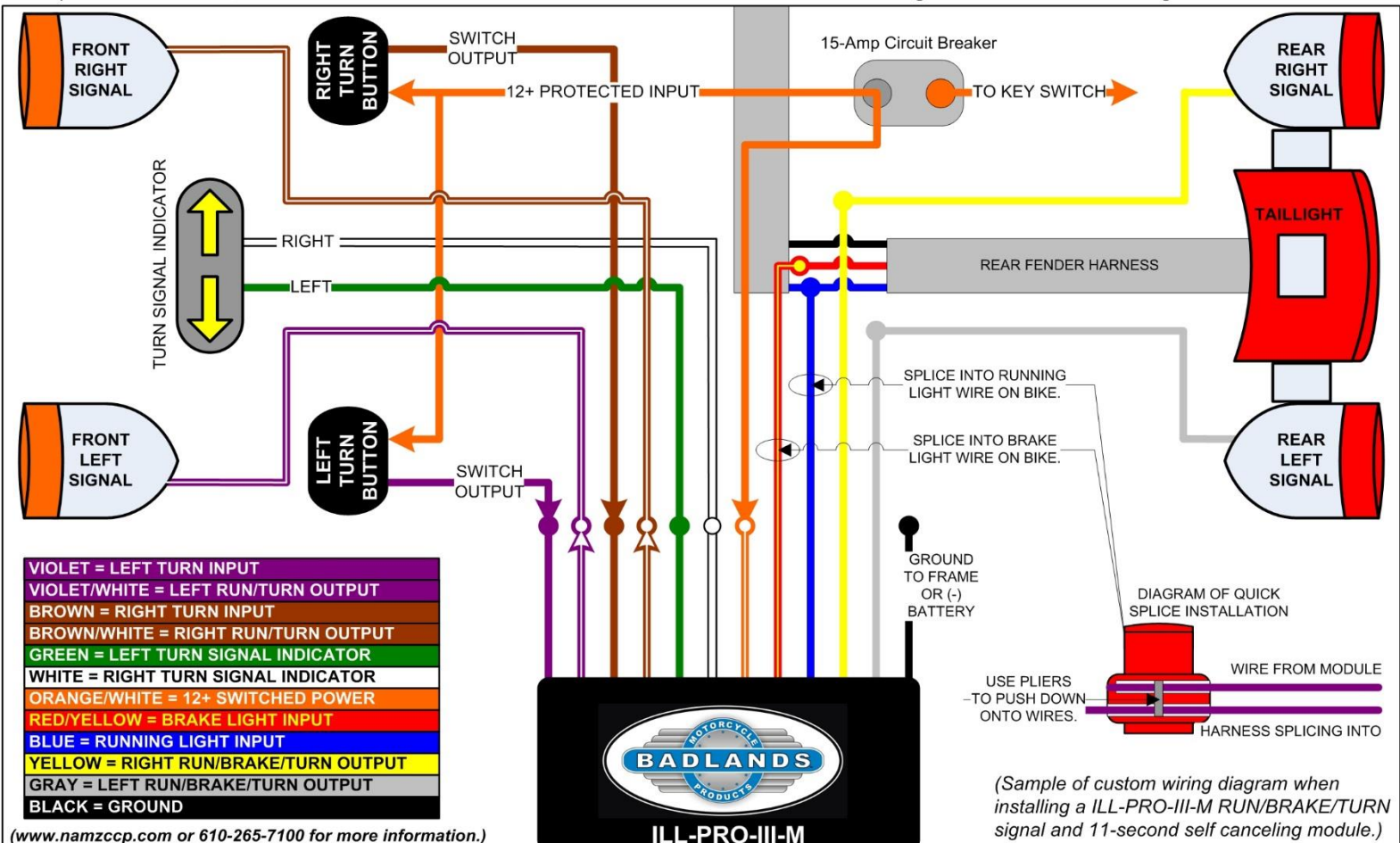

BADLANDS LE-02-M (HONDA ONLY) and MLE-04 (ALL) Metric Load Equalizer Modules

Thank you for purchasing a Badlands Load Equalizer Module! We're sure that you will be completely satisfied with the performance and ease of installation of your new module. Before you get started, PLEASE read these instructions and helpful tips so that you understand how to install your module correctly. An improper installation will void the warranty.

FEATURES: All Badlands Load Equalizer Modules are designed to provide you the ability to use small incandescent bulbs, Halogen bulbs or LED style turn (*module operates both front & rear*) signals without a rapid flash. A "rapid-flash" is caused by the factory turn signal module not seeing the specific amperage draw that the factory bulbs provided. Now you understand the features of our Load Equalizer Module, let's talk about how it works.

INSTALLATION: You can use any installation method you choose but **DO NOT** disconnect the battery! We package these versions with (1) ring terminal and (2) quick splices but we recommend using connectors and terminals whenever possible. Now lets talk about connecting the wires. As you can see in the drawing below, it is easiest to install the LE-02-M and MLE-04 near either the front signal harness or rear fender harness connection. The rear fender harness should ALWAYS have the following wires in it; running light, brake light, ground, left turn signal and right turn signal. Use the supplied quick splices to "splice" the right and left module wires with the LEFT TURN signal wire and the RIGHT TURN signal wire in the harness. The diagram below shows you how to "splice into" these (2) wires while still keeping the wires connected as they were from the factory. We recommend connecting the ORANGE wire from the MLE-04 directly to the battery with a 7.5 AMP fuse or to a protected circuit on your bike. Be sure to connect the BLACK wire directly to the battery as shown or a good frame ground.

LE-02-M: Hard-wired module and is intended specifically for Honda Motorcycles. It has been designed to not overheat just in case you leave your signal on for 17-miles! Runs custom incandescent small turn signals, halogen and LEDs as well. Runs mixed front & rear with your turn signal flashing.

MLE-04: Hard-wired module and is perfect for most metric motorcycles (except Hondas) to solve the rapid flashing problem that occurs when custom lights or LEDs replace factory turn signals. Compatible with virtually any custom turn signal available & works great with small incandescent or halogen bulbs and LED's as well. This module is also solid-state and will not generate any heat.

There is **NO** warranty WHATSOEVER on the LE-02-M Modules. The manufacturer nor the seller assumes any responsibility or liability for damage caused by inappropriate use by the consumer/operator or installer.

APRILIA	
Light Blue:	Left Turn
Red:	Right Turn

BUELL	
Violet:	Left Turn
Brown:	Right Turn

DUCATI	
White/Black:	Left Turn
White/Green:	Right Turn

HONDA	
Orange:	Left Turn
Light Blue:	Right Turn

KAWASAKI	
Green:	Left Turn
Gray:	Right Turn

SUZUKI	
Black:	Left Turn
Light Green:	Right Turn

TRIUMPH	
Green/Red:	Left Turn
Green/White:	Right Turn

YAMAHA	
Brown:	Left Turn
Dark Green:	Right Turn

